



250 Series Professional Shotgun Microphones

Affectionately known in Japan as “Ni-Go-Maru” (Japanese for “250”), the Azden 250 Series Professional Shotgun Microphones deliver professional-grade performance and world class build quality at an affordable price.

Professional-Grade Performance

Low noise, full-range frequency response and a narrow supercardioid pickup pattern for professional dialogue capture.

Sonic Consistency

While each microphone model has its own unique physical characteristics, users can expect the same superb sound quality and side-noise rejection across the board. That’s because each model uses the same high-quality microphone element and the same length interference tube.

Series Versatility

The four models in the 250 Series are suited for a number of different applications, ranging from boom pole mounting to a variety of different on-camera mounting situations.

World Class Build Quality Backed by 10-Year Warranty

Each microphone is assembled by hand in Azden’s factory in Japan. This craftsmanship is backed by a 10-year warranty.

Affordability

Models in the 250 Series fall in a very attainable price range from \$199 to \$249 (in the US).

Natural Sound

The 250 series microphones have become notable in the industry for their natural, professional sound. While other microphone manufacturers hype-up the bass response, making the audio sound muddy, or over-accentuate high-mids, making dialogue tracks sound harsh, users can expect all of the 250 Series microphones to accurately record the sound of their scenes.

SGM-250



Professional Dual-Powered Shotgun Mic

Powered by either phantom power or a AA battery without any loss in performance, it works great for booming or camera-mount applications.

SGM-250P



Professional Shotgun Microphone

This phantom powered only model is a great choice for those more budget conscious users who want a solid XLR shotgun microphone.

SGM-250CX



Professional Compact Cine Mic

The perfect cinema camera microphone, it measures just 6 inches in length and comes with an attached XLR cable.

SGM-250MX



Professional Compact Cine Mic w/ Mini-XLR

Short like the CX model, it’s the only microphone compatible with the Mini XLR input on the Blackmagic Pocket Cinema 4K and 6K Cameras.



250 Series Shotgun Microphones



SGM-250 / SGM-250P / SGM-250CX / SGM-250MX

Series Highlights

- Newly developed condenser microphone element delivers the best sensitivity and lowest noise in its class
- Custom designed acoustic tube with high-precision phase canceling slots produces a flat frequency response with excellent directionality and wide dynamic range
- Powered by standard 48 V DC phantom power
- Brass/aluminum alloy case for improved durability and resistance to ambient RF
- Gold plated, 3-pin XLR output connector
- 10 year warranty with online registration

INCLUDED ACCESSORIES



OPTIONAL FURRY WINDSHIELDS



FREQUENCY RESPONSE

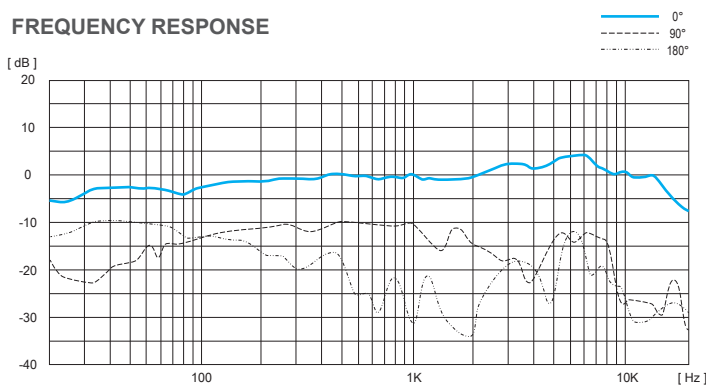

POLAR PATTERN

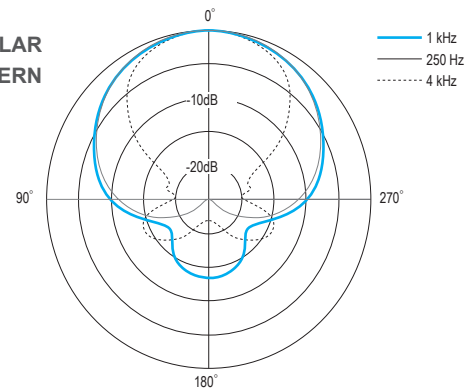

SPECIFICATIONS AND COMPARISONS

	SGM-250	SGM-250P	SGM-250CX	SGM-250MX
Retail Price	\$249.00	\$229.00	\$199.00	\$199.00
Frequency Response	20 Hz - 20 kHz	20 Hz - 20 kHz	20 Hz - 20 kHz	20 Hz - 20 kHz
Polar Pattern	Supercardioid	Supercardioid	Supercardioid	Supercardioid
Sensitivity	-38 dB	-38 dB	-33 dB	-33 dB
Impedance	120 Ω	120 Ω	100 Ω	100 Ω
Low-cut Filter	160 Hz / 3 dB per octave	160 Hz / 3 dB per octave	N/A	N/A
Phantom Power	48 V	48 V	48 V	48 V
Battery Option	1 x AA Battery	N/A	N/A	N/A
LED Power Ind.	Yes	No	No	No
Length	9.8" (250 mm)	7.9" (200 mm)	6.0" (153 mm)	6.0" (153 mm)
Diameter	0.83" (21 mm)	0.83" (21 mm)	0.83" (21 mm)	0.83" (21 mm)
Weight	5.7 oz	3.2 oz	3.0 oz	3.0 oz
Output	3-pin XLR	3-pin XLR	3-pin XLR	3-pin Mini XLR
Cable Length	N/A	N/A	13" (33 cm)	13" (33 cm)

AZDEN CORPORATION

200 Valley Rd STE 101, Mt. Arlington, NJ 07856 • T: +1 973 810 3070 • F: +1 973 810 3076 • email: sales@azden.com

LEARN MORE ABOUT AZDEN PRODUCTS AT www.azden.com