

SPECIFICATIONS

IRR-40P	2-channel receiver w/power amplifier	
	Sub-carrier frequencies	2.06MHz & 2.56MHz
	Type	Super heterodyne – crystal controlled
	Modulation	FM
	Pilot Tone Signal	32.768kHz
	Frequency Response Deviation	50-10kHz \pm 3dB / less than 1%
	Audio Output	RCA Jack Mono x2
	Speaker Out	5W x4 @4 Ohms
	Line Input	RCA Jack (L & R)
	Sensor Input	F-connector x3
	Power requirement	15V DC @ 2.7A (use model BC-30)
	Size	8.03" W x 9.19" D x 1.73" H (204 x 233 x 44mm)
	Weight	3.3lb (1.5kg)
IRH-15c	2-channel handheld transmitter	
	Sub-carrier frequencies	2.06MHz & 2.56MHz switchable
	Modulation	FM
	Microphone element type	Uni-directional dynamic
	Frequency Response	50-8kHz \pm 3dB
	Battery type	2-"AA" alkaline(1.5V x 2)
	Battery life	2-"AA" rechargeable Ni-MH (1.2V x 2)
	Size	> 6 hours w/alkaline batteries
	Weight	9.65" x ~1.375" (245 x ~35mm)
		9.1oz (258g) w/alkaline batteries
IRN-10	2-channel chest-worn transmitter	
	Sub-carrier frequencies	2.06MHz & 2.56MHz switchable
	Modulation	FM
	Microphone element type	Uni-directional electret x 2
	Frequency response	50-9kHz \pm 3dB
	Ext Mic input impedance	2.2k ohms
	Ext Mic input jack	Φ 3.5mm
	Ext. Mic Voltage/Current	3.5VDC @ 1mA (to power electret mic element)
	Mic gain adjustment	+6dB ~ -10dB
	Battery type	2-"AA" Alkaline (1.5V x 2)
	Battery life	2-"AA" rechargeable Ni-MH (1.2V x 2)
	Size	> 8hours w/alkaline batteries
	Weight	3.15" H x 2.75" W x 1.06" D (80 x 70 x 27mm)
		4.3oz (120g) -w/alkaline batteries
IRD-60	Dome sensor	
	Output	F Connector
	Power	powered by receiver (24V @ 15mA)
	Cable requirement	RG59 - 75 ohms coaxial
	Size	3.94" x 1.18"(100x30mm)
	Weight	6.00oz (170g) w/mounting bracket

User's Guide

INFRARED CLASSROOM SYSTEM

IRR-40P RECEIVER • IRN-10 MIC/TRANSMITTER

IRH-15c MIC/TRANSMITTER • IRD-60 EXTERNAL SENSOR



Azden Corporation, 200 Valley Road, Suite 101, Mt. Arlington, NJ 07856
phone – 973.810.3070 • fax – 973.810.3076 • email – sales@azden.com



IRR-40P

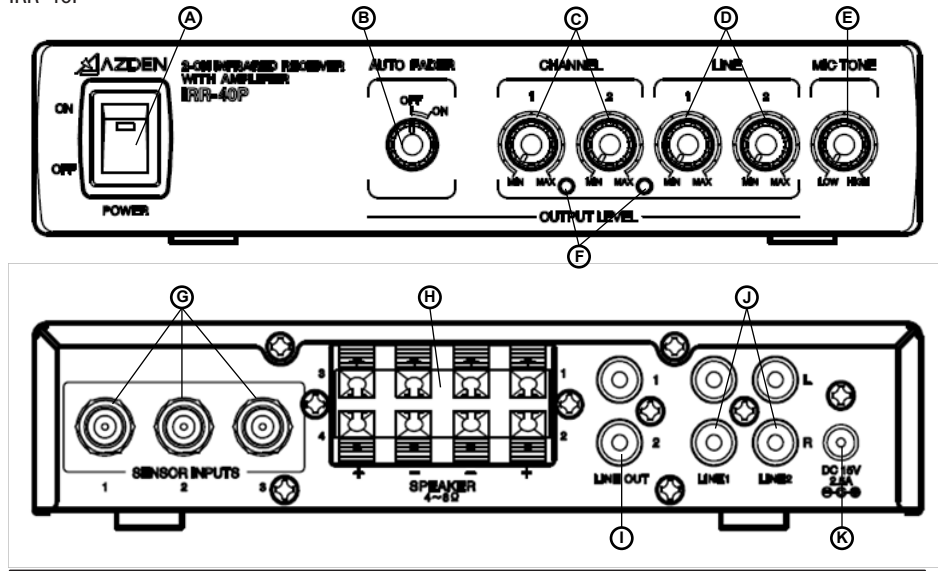

IRN-10

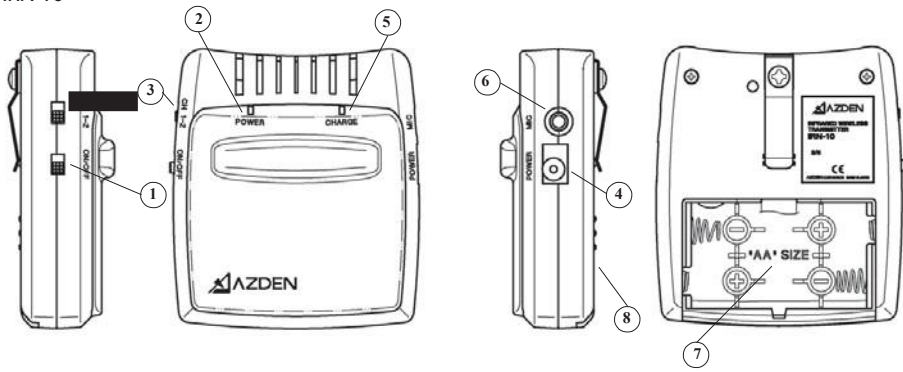

IRH-15c

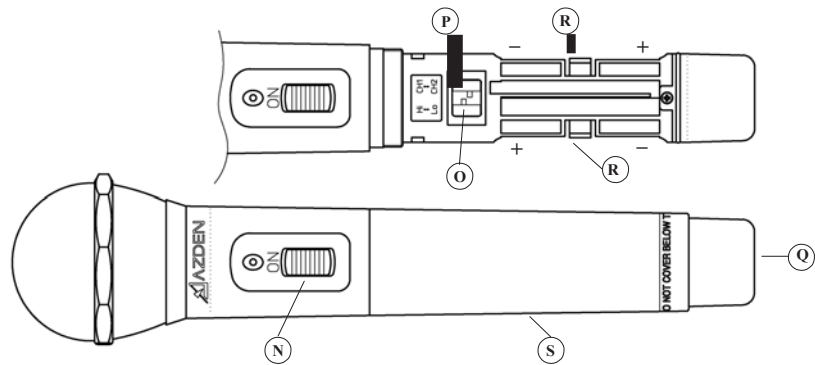

IRN-20 MICROPHONE/TRANSMITTER

The IRN-20 microphone/transmitter may be substituted for the IRN-10 in Azden's classroom systems that use IRR-30P and IRR-40P receivers. Operation of the IRN-20 is very similar to that of the IRN-10 with one main additional feature: the IRN-20 has a remote volume control which may be used to increase or decrease the volume of the speaker's voice over the system. *This volume control feature will only work when using the IRR-40P receiver.*

It should also be noted that the IRN-20 requires a different charger than the one that works with the IRN-10. If you would like to add the IRN-20 to your system, *be sure to order the compatible BC-31 charger.*

IRN-20 Features

- Remote volume control (with IRR-40P only)
- Operates on just 1 AA battery, either alkaline or rechargeable NiMH
- Uses two microphones for a wide pick-up pattern; provides a constant volume level as the user's head is turned from side to side
- Auxiliary input jack (3.5mm stereo) allows for audio playback from smartphones, tablets, computers, DVD players, etc.
- LED status indicator lets the user know when the battery needs charging, or is charged.
- External microphone jack
- Includes adjustable neck strap

For more information on the IRN-20 please contact your Azden dealer or the Azden sales department at sales@azden.com.



INTRODUCTION

Thank you for selecting the Azden **INFRARED** system as your wireless classroom solution. We are confident that it will perform beyond your expectations. For over 50 years Azden Corporation has been creating technologically advanced products. By taking advantage of the latest in CAD design and SMT production techniques, Azden's engineers are able to produce products that exceed the published specifications and perform well beyond the warranty period.

Azden **INFRARED** represents a breakthrough in wireless: Instead of the normal radio waves that other wireless systems use, Azden **INFRARED** uses invisible light beams in the infrared range. **INFRARED**'s enhanced performance assures you of the finest in audio clarity and reliability. The specially selected high-frequencies provide you with trouble free performance, even in fluorescently lit classrooms.

Infrared (IR) wireless microphone systems are the best solution for classrooms. In today's RF saturated world a regular (VHF or UHF) microphone system risks interference from a variety of other devices and sources. Cell phones, radios, TV, PA systems, police and emergency service systems, etc., can all interfere with VHF and UHF - but not with IR. Furthermore, infrared is perfect for classroom audio since, unlike the other systems, IR is short-range and cannot penetrate walls. This means that your school can have as many classrooms as desired with individual audio systems, without fear of interference. Since the Azden system is dual-channel, a teacher can have one microphone and a second person can have another microphone. In addition, since each classroom system is on the same pair of channels, teachers can go from room to room without having to switch microphones.

In the real world, the ability to use multiple systems in the same location without frequency interference will prove to be a tremendous benefit to you. Using infrared means that the audio generated in your classroom stays in your classroom. Your discussions cannot be overheard on other systems in other classrooms.

Designed by professionals - for professionals, Azden **INFRARED** will provide you with years of worry-free, high-quality performance.

TABLE OF CONTENTS

ILLUSTRATIONS	i
INTRODUCTION	ii
IRR-40P RECEIVER	1
Receiver front panel	1
Receiver rear panel	1
Mounting the receiver	1
Overall System Setup	1
IRH-15c MIC/TRANSMITTER	2
Batteries and Power Mode for the IRH-15c	2
Frequency selection	2
Using the IRH-15c	2
IRN-10 MIC/TRANSMITTER	2-3
Batteries for the IRN-10	2
Frequency selection	2
Using the IRN-10	3
External Mic Jack	3
INTERNAL CHARGING	3
IRD-60 SENSOR	4
TROUBLESHOOTING	5
THE IRN-20 MIC/TRANSMITTER	6
SPECIFICATIONS	back cover

TROUBLESHOOTING

The single most important thing to **ALWAYS** check when trouble arises are the batteries. Make sure they are fresh and the **POWER LED** is glowing brightly.

SYMPTOM	CAUSE
No POWER LED	<ul style="list-style-type: none"> a. Receiver switch is set to OFF - change to ON b. External 15VDC power source is not connected or is malfunctioning c. Dead or very weak battery in transmitter
No audio from IRN-10	<ul style="list-style-type: none"> a. Make sure the volume on the receiver is turned up for the appropriate channel and the IRN-10 is powered ON b. If two transmitters are being used, make sure they are set to different frequency channels c. Make sure the batteries are fresh or fully charged and installed correctly
No audio from IRH-15c	<ul style="list-style-type: none"> a. Make sure the volume on the receiver is turned up for the appropriate channel and the IRH-15c is powered ON b. If two transmitters are being used, make sure they are set to different frequency channels c. Make sure the batteries are fresh or fully charged and installed correctly
Intermittent audio	<ul style="list-style-type: none"> a. Make sure there is a clear path between the transmitter and the receiving sensor. Best results are obtained when the receiving sensors are mounted high - above everyone's head
Limited working range	<ul style="list-style-type: none"> a. Install extra external sensors b. If using IRH-15c set the Power Mode to Hi

IRD-60 SENSOR

The **IRD-60** is an externally-mounted IR sensor. Its purpose is to receive the IR signal from the **IRN-10** and/or the **IRH-15c** and send it to the input of the **IRR-40P** for amplification. The ideal location of the **IRD-60** is the center of the ceiling in the room. A cable (RG-59 75 ohm coaxial cable fitted with "F" connectors) is then run from the **IRD-60** to the back of the **IRR-40P**. The sensor comes with a mounting-bracket that can be used for mounting to either a solid or drop ceiling (tiles).

Drop Ceiling Mount:

To mount to a drop-ceiling tile, detach the bracket (9) from the back of the **IRD-60** by removing the screws (10). Next, after removing the ceiling tile from the ceiling grid, determine the position on the tile panel for the sensor and make a 1 inch hole through the tile (this is for the cable that will be attached). Then sandwich the tile between the sensor (on the front side) and the bracket (on the back side). Use the two mounting screws to attach. Last, attach the cable and replace the tile.

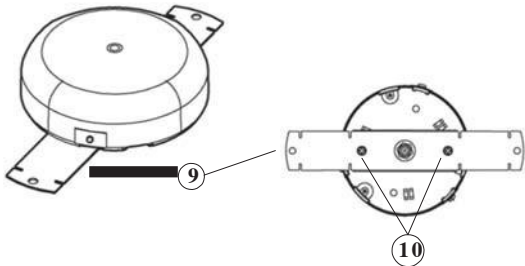

When mounting to a solid ceiling, first bend the mounting bracket UP at a 90° angle (11). Next, bend the ends of the bracket to a 90° angle (12). After attaching the cable to the back of the **IRD-60**, use the appropriate screws (13) to attach the bracket to the ceiling.

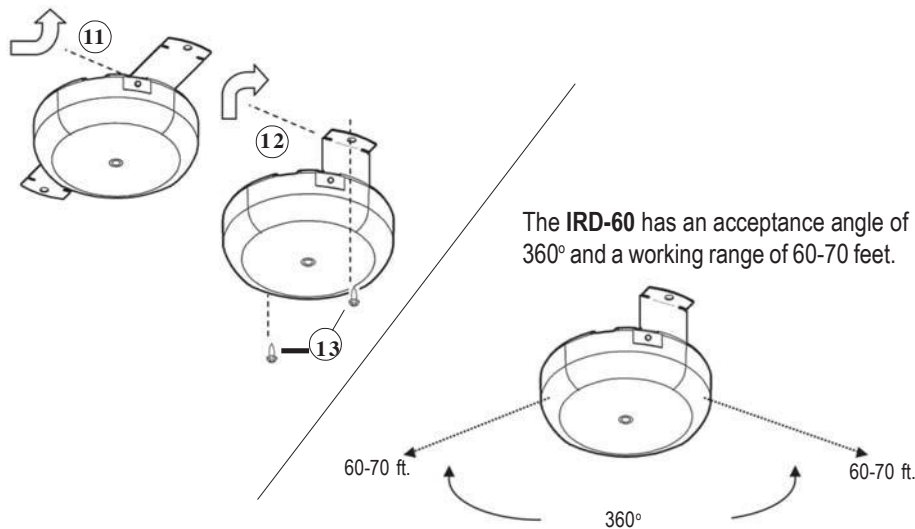

IRR-40P RECEIVER (see illustration on page i)

I. Receiver Front Panel:

- A. **POWER Switch** - turns the receiver ON and OFF. When ON the LED will glow red.
- B. **AUTO FADER Switch** - turns the AUTO FADER ON and OFF. When ON, speaking into the microphone (either Channel 1 or 2) will mute the sound from LINE IN 1 and/or 2.
- C. **CHANNEL 1/2 Volume** - Adjusts the output volume level for CHANNEL 1 or 2.
- D. **LINE 1/2 Volume** - Adjusts the output volume level for LINE 1 or 2.
- E. **MIC TONE Control** - Adjusts the system's high frequency tone.
- F. **CHANNEL 1/2 Indicator** - Corresponding LED glows green when CHANNEL 1 or 2 is activated.

II. Receiver Rear Panel:

- G. **SENSOR INPUTS** - Attach the IR sensor(s) IRD-66 and/or IRD-36 here using the RG-59 cable(s) (not included). IMPORTANT: Plug the unused inputs using the supplied shorting plugs. Failing to do so will severely reduce the working range of the sensor(s).
- H. **SPEAKER Connectors** - The ceiling or wall-mounted speakers will be connected here. Carefully follow the + and - markings (speaker cables are not included).
- I. **LINE OUT Outputs** - Outputs the sound to other devices. Accepts RCA plugs.
- J. **LINE 1/2 Inputs** - Any external audio source with a standard "Line-Level" output, such as a CD or MP3 player, DVD player, etc. may be attached here.
- K. **Power Supply Jack** - This is the power input. Plug the small, round connector of the supplied AC-DC adaptor (BC-30) into the Power Supply Jack.

III. Overall System Setup:

Four ceiling speakers (if there is a drop ceiling grid) or four wall-mounted speakers are installed and wire is run from each of the speakers to one of the **SPEAKER** terminals on the back of the receiver. A single **IRD-60** ceiling-mount external sensor is installed in the center of the ceiling and a cable is attached from it to one of the **EXTERNAL SENSOR** connections on the rear of the **IRR-40P**. The teacher wears the **IRN-10** and sets it to **CHANNEL 1**. The **IRH-15c**, set to **CHANNEL 2**, is used as a pass around mic for students. If a DVD player, CD player or video tape player is used, its audio can be attached to either **LINE 1** or **LINE 2** on the back of the **IRR-40P**.

IRH-15c MICROPHONE/TRANSMITTER (see illustration on page i)

Batteries and Power Mode:

The **IRH-15c** uses two "AA" batteries. Batteries are placed in the battery compartment after unscrewing and removing the bottom portion of the microphone handle (**S**). The **IRH-15c** can use either 2 "AA" NiMH*, or Alkaline batteries. Place the two batteries into the transmitter as shown (**R**). OBSERVE PROPER POLARITY! Be sure to use FRESH "AA" Alkaline batteries or, in the case of "AA" rechargeable batteries, be sure that they are FULLY CHARGED (overnight) before use. Battery life depends on the type of battery and the position of the "Hi-Lo" power switch (**O**). Maximum battery life is achieved with the switch in the "Lo" position.

*See the section on "**Internal Charging**" for more battery information.

Frequency Selection:

The **IRH-15c** can be set to transmit on either one of two preset frequencies. This allows two microphones to be used at the same time in the same room. While it does not matter which frequency is chosen for the **IRH-15c**, two transmitters cannot share the same frequency at the same time. To select the channel, slide the switch (**P**) as shown on the sticker inside the battery compartment to the desired position.

Using the IRH-15c Microphone/Transmitter:

After installing fresh batteries and choosing a frequency, simply turn the microphone/transmitter on by sliding the **ON/OFF** (**N**) switch up. The green Power LED above the switch will glow as will the green LED on the front panel of the **IRR-40P** receiver which corresponds to the chosen channel (**C**). Be sure to slide the Power Switch to **OFF** when not in use to preserve battery life. When talking, this microphone should be held close to the user's mouth, ideally just under the chin.

IRN-10 MICROPHONE/TRANSMITTER (see illustration on page i)

Batteries:

The **IRN-10** uses two "AA" batteries. Batteries are placed in the battery compartment after sliding the battery compartment door (**8**) down and away. The **IRN-10** can use either 2 "AA" NiMH*, or Alkaline batteries. Place the two batteries into the transmitter as shown (**7**). OBSERVE PROPER POLARITY! Be sure to use FRESH "AA" Alkaline batteries or, in the case of "AA" rechargeable batteries, be sure that they are FULLY CHARGED (overnight) before use. See the section on "**Internal Charging**" for more battery information.

Frequency Selection:

The **IRN-10** can be set to transmit on either one of two preset frequencies. This is so that two microphones can be used at the same time in the same room. While it does not matter which frequency is chosen for the **IRN-10** microphone, two transmitters cannot share the same frequency at the same time. To select the channel, slide the switch (**3**) to the desired position.

Using the IRN-10 Microphone/Transmitter:

After installing fresh batteries and choosing a frequency, simply turn the microphone/transmitter on by sliding the **ON/OFF** (**1**) switch up. The green Power LED (**2**) will glow as will the green LED on the front panel of the **IRR-40P** receiver which corresponds to the chosen channel (**C**). Be sure to slide the Power Switch to **OFF** when not in use to preserve battery life. This microphone should be worn using the supplied lanyard and be positioned approximately six inches from the users mouth.

External Microphone Jack:

If an external microphone is desired, plug it into the mic input (**6**); the internal microphones will be automatically disabled.

INTERNAL CHARGING

The **IRN-10** and **IRH-15c** can all be used with rechargeable NiMH or regular Alkaline "AA" batteries. While regular rechargeable NiMH batteries can be charged after taking them out of the unit, Azden's **1HR-3U** batteries can be charged without removing them. Both the **IRN-10** and **IRH-15c** use a special safety interlock system that prevents the accidental attempt to charge non-rechargeable (Alkaline) batteries. The special NiMH batteries have a portion of their wrapping removed so that they can be identified as "rechargeable." Charging requires an AC/DC adaptor (Azden's **BC-29**). To charge, plug the charger adaptor into 110VAC outlet and plug the connector into the transmitter (**4**) on the **IRN-10** and (**Q**) on the **IRH-15c**. Make sure the transmitter is in the **OFF** position. Allow a minimum of 12 hours to charge the batteries (overnight). The NiMH rechargeable batteries can operate either transmitter for 6-8 hours.